

NO	QTY	PART NO	DESCRIPTION	STD SEAL KIT	FKM SEAL KIT
1	1	21500010	SCREW, CAP, BTNH, M12 X 20, ALY		
2	2	21500019	SCREW, CAP, BTNH, M3 X 6, ALY		
3	2	21500200	WASHER		
4	3	23600002	BALL, STEEL, ALLOY, .250	X	X
5	1	39011030	SEAL,CROWN,1-1/16x1-1/4x5/32	X	39V11030
6	1	39011046	SEAL,BEVEL W/HEEL INSERT,7/8 x1/8 x1 1/8	X	39052003
7	2	39050042	O-RING, (-011)	X	39051025
8	1	39053000	WIPER,SNAP-IN, (7/8)	X	X
9	2	43068006	PLUG, PORT, HOLLOW HEX, G1/4		
10	1	47511313	PLUNGER,SC,HS,11.6KN,LH,LS		
11	1	81400030	RETAINER,SC,HS,2600		
12	3	90199958	ASSY,BALLSEAT,SC,2600/5000	X	X
13	1	39F54002	BU RING, (-212 CUSTOM)	X	X
14	1	39V51043	O-RING, (-918)	X	X
N/A	N/A	60414504	KIT, SEAL, STANDARD		
N/A	N/A	6V414504	KIT, SEAL, FKM		

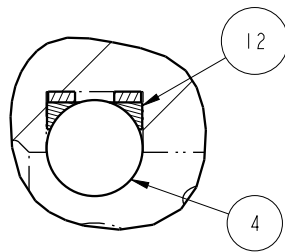

DETAIL A
SCALE 2.000

PARTS LIST

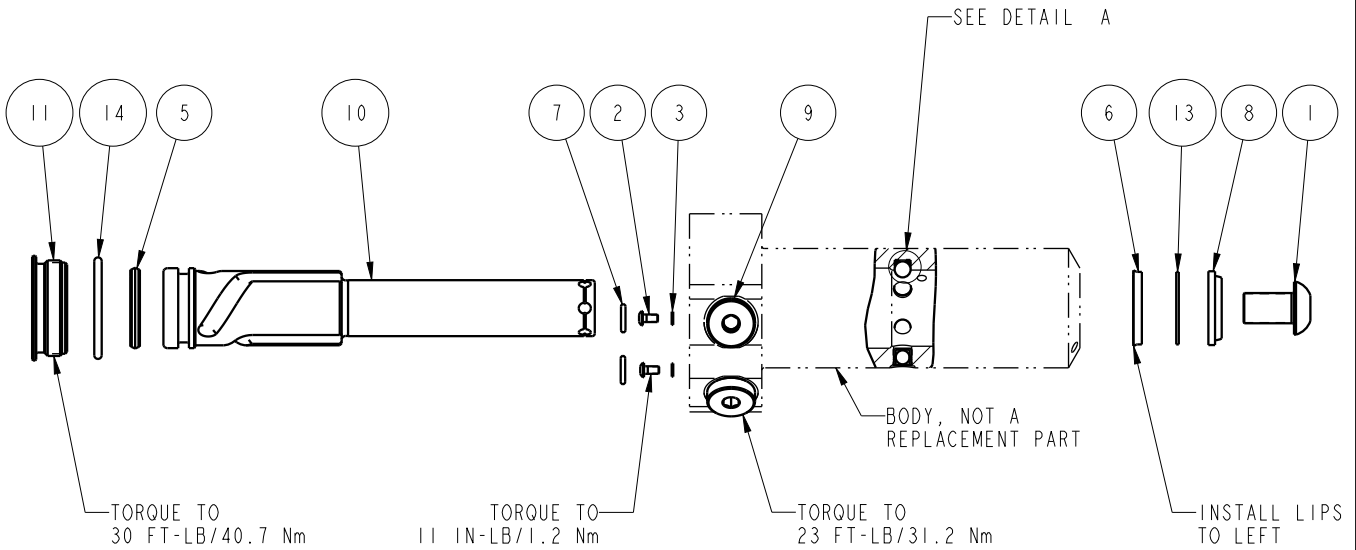

VEKTEK, INC.
1334 E. SIXTH AVE. P.O. BOX 625
EMPORIA, KS. 66801 U.S.A.

ASSEMBLIES AFFECTED
41421124

PARTS LIST, ASSY, SC, BF, TC, 11.6KN, DA, LH, LS

D	5279	RELEASE	ALS	4/22/24
REV	IN ACCORDANCE WITH ECN	EFFECTIVE DATE	REVISED BY	DATE
DRW BY:	JDW	DRAWING STATUS: Released		
DATE:	12/3/11	PRODUCTION APPROVED FOR RELEASED STATUS ONLY		

SIZE A	MPLV1444	REV D
-----------	----------	----------

FORM FEG035_PL_ASIZE, REV. B

SHEET 1 OF 1